

On Properties of Double Laplace Transformation for Analysis of Linear Time-Varying Systems

Shervin Erfani

Research Centre for Integrated Microelectronics
Electrical and Computer Engineering Department
University of Windsor
Windsor, Ontario N9B 3P4, Canada

June 10 2011

Outline of the Presentation

- Objectives
- Operational Calculus: **A Bit of History**
- Dynamic System Characterization
 - Volterra Formalism: Power Series Expansion
 - Impulse Response and **Laplace** Formalisms
- Linear Time Varying System Characterization
 - Fundamental Theorems
 - Double Laplace Transformation
 - Properties of 2DLT
- Associated Transforms : **2D-to-1D Reduction**
- Concluding Remarks

Objectives

- ❖ Our goal in this research is to develop frequency-domain techniques for analyzing linear time-varying (LTV) systems with a wide variety of inputs and responses.
 - Transforming LTV systems, **element by element**, into the *frequency plane*
- ❖ Another objective is to **reintroduce** the application of **multidimensional Laplace transform (MDLT)**, in general, and **double Laplace transform (2DLT)** techniques, in particular, for analyzing the nonlinear system and LTV system, respectively.
 - Transforming differential equations with **variable coefficients**



Why Operational Calculus

- Operational calculus, stimulated by Heaviside's ingenious work, provides a systematic operational method into analysis of physical and technical problems.
 - Leads to transformation techniques
- The practical significance of transform methods facilitates observation of **a great many properties** and **hidden views**, of both mathematical and physical interest, which are not yet very well known and have not met with proper appreciation.
 - Leads to simple analysis and synthesis techniques

Oliver Heaviside

Oliver Heaviside (18 May 1850 – 3 February 1925) was a self-taught English electrical engineer, mathematician, and physicist who adapted complex numbers to the study of electrical circuits, invented mathematical techniques to the solution of differential equations (later found to be equivalent to Laplace transforms), reformulated Maxwell's field equations in terms of electric and magnetic forces and energy flux, and independently co-formulated vector analysis. Although at odds with the scientific establishment for most of his life, Heaviside changed the face of mathematics and science for years to come.

“The first 13 years of my life I lived in miserable poverty ... the effect was ... disastrous and permanently deformed my life.” -O. Heaviside

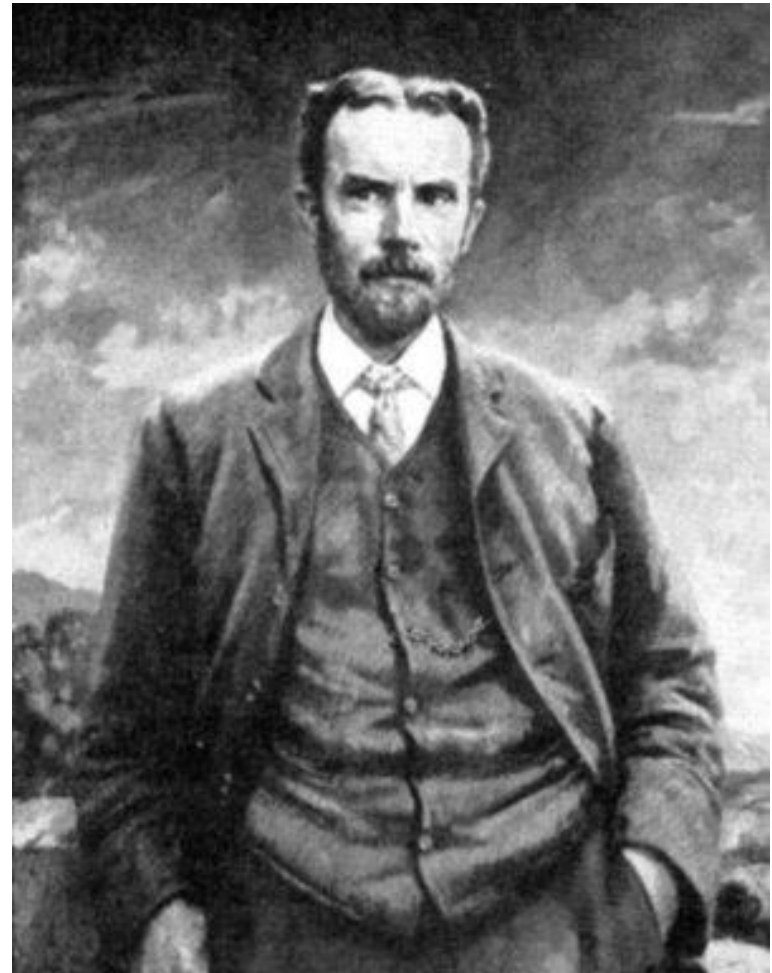

System Operator

- The system operator Ω maps, according to some specified rule, the input functions into the output functions.
- The operator Ω is an integrodifferential equation and the auxiliary condition that satisfy the initial condition.
- The operator may be classified as **homogeneous**, **linear**, **deterministic**, **causal**, **nonanticipative**, etc.

$$\Omega(\langle x, y \rangle) = \Omega\left(x, \dot{x}, \ddot{x}, \dots, x^{(p)}; y, \dot{y}, \ddot{y}, \dots, y^{(q)}\right) = 0,$$

The important thing about a problem is not its solution, but the strength we gain from the solution.

Dynamic System Characterization

- Taylor expansion cannot be used to represent nonlinear systems with memory (**why?**).
- Vito Volterra has developed a practical method [**Volterra 1930**]:
 - Let $H(t, \tau) = 0$ represent an algebraic relation,
 - Let the two variables be replaced by two functions $x(t, \tau)$ and $y(t, \tau)$,
 - Let all multiplications of t with itself or with τ be replaced by composition of the corresponding functions as:

$$x * y = \int x(t, \xi) y(\xi, \tau) d\xi$$

- Now, it is possible to expand the original function $H(., .)$ in power series of t and τ , when they have been replaced by $x(t, \tau)$ and $y(t, \tau)$ and multiplications by convolutions.
- This will yield the response $y(t)$ as an integral equation!

❖ V. Volterra, *Theory of Functionals and of Integral and Integro-Differential Equations*, Blackie, London, UK, 1930 (Dover Phoenix Editions, New York, NY, 2005).

Vito Volterra

- **Vito Volterra** (3 May 1860 – 11 October 1940) was an [Italian mathematician](#) and [physicist](#), known for his contributions to [mathematical biology](#) and integral equations.
- Born in [Ancona](#), then part of the [Papal States](#), into a very poor [Jewish](#) family, Volterra showed early promise in [mathematics](#) before attending the [University of Pisa](#), where he fell under the influence of [Enrico Betti](#), and where he became professor of rational mechanics in 1883. He immediately started work developing his theory of [functionals](#) which led to his interest and later contributions in [integral](#) and integro-differential equations. His work is summarized in his book *Theory of functionals and of Integral and Integro-Differential Equations* (1930).



Deterministic System

A deterministic system whose output is a single-valued function of the input is characterized by the functional formalism

$$y(t) = H[x, t]$$

Lemma 1 [Parente 1970]– A system S is time-invariant deterministic if and only if there exists a functional H such that, for all real t and each admissible input-output pair,

$$y(t) = H[x(t - \tau)] \Big|_{\tau=t_0}^{t_f}$$

where t_0 and t_f are real constants and $-\infty < t_0 \leq t_f < \infty$.

- **The closed interval $[t_0, t_f]$ is the system *memory*.**
- **If $t_0 = t_f = 0$, the system is *memoryless*.**
- **If $t_0 = t_f > 0$, the system is a *delay*.**
- **If $t_0 \geq 0$, the system is *causal and realizable*.**
- **If $t_0 \leq 0$, the system is *anticipative and unrealizable*.**

❖ R. B. Parente, "Nonlinear differential equations and analytic system theory," *SIAM J. Applied Math*, vol. 18, pp. 41-66, 1970.

Causal System

Theorem 2 [Erfani 2010]– A SISO system S is a causal autonomous deterministic system **if and only if** there exists a functional H such that for all real t and τ and each admissible input-output pair,

$$y(t) = H[x(|t - \tau|)] \Big|_{\tau=\tau_0}^{\tau_f}, \quad \forall \quad -\infty \leq \tau_0 \leq \tau_f \leq \infty$$

where either τ_0 or τ_f might include infinity, and $|\cdot|$ denotes an arbitrary **norm** (or **length**) of the quantity within the bars.

❖ **Definition** - A **causal function** is defined as a function of a **norm of the real time vector t** .

- ❖ S. Erfani and N. Bayan, "Frequency analysis of linear time-varying systems," *Proc. IEEE ICECS 2010*, pp. 1116-1119, Athens, Greece, Dec. 12-15, 2010.

Analytic System

Lemma 2 [Wiener 1942]– For any SISO analytic deterministic system S , there exists a Volterra functional power series representation of the form:

$$y(t) = h_0(t_0) + \int_{-\infty}^{\infty} h_1(t_1)x(t-t_1)dt_1 + \int_{-\infty}^{\infty} \int_{-\infty}^{\infty} h_2(t_1, t_2)x(t-t_1)x(t-t_2)dt_1 dt_2 + \dots$$

$$y(t) = \lim_{n \rightarrow \infty} \sum_{i=0}^n \int_{t_0}^{t_f} \int_{t_0}^{t_f} \dots \int_{t_0}^{t_f} h_i(\xi_1, \xi_2, \xi_3, \dots, \xi_i) \prod_i [x(t-t_i) d\xi_i]$$

- This power series expresses the output of a variable dynamic system in terms of **powers of the input**.
- Each term is a convolution and is called the homogenous functional of the i -th degree.
- The kernels are not unique, but can be found uniquely if assumed to be symmetric and related to the functional derivatives.
- If the **input function** is taken to be a **delta function**, this gives the **impulse response**.
- The i -th Volterra kernel of the system, h_i , is the i -th order impulse response function of $t_1, t_2, t_3, \dots, t_i$ real variables.

❖ N. Wiener, "Response of a nonlinear device to noise," M.I.T. Radiation Lab., Report 129, Cambridge, MA, Apr. 6, 1942.

Norbert Wiener

- **Norbert Wiener** (November 26, 1894, [Columbia, Missouri](#) – March 18, 1964, [Stockholm, Sweden](#)) was an [American mathematician](#).
- A famous [child prodigy](#), Wiener (*pronounced WEE-nur*) later became an early studier of [stochastic](#) and [noise](#) processes, contributing work relevant to [electronic engineering](#), [electronic communication](#), and [control systems](#).
- Wiener is regarded as the originator of [cybernetics](#), a formalization of the notion of [feedback](#), with many implications for [engineering](#), [systems control](#), [computer science](#), [biology](#), [philosophy](#), and the organization of [society](#).

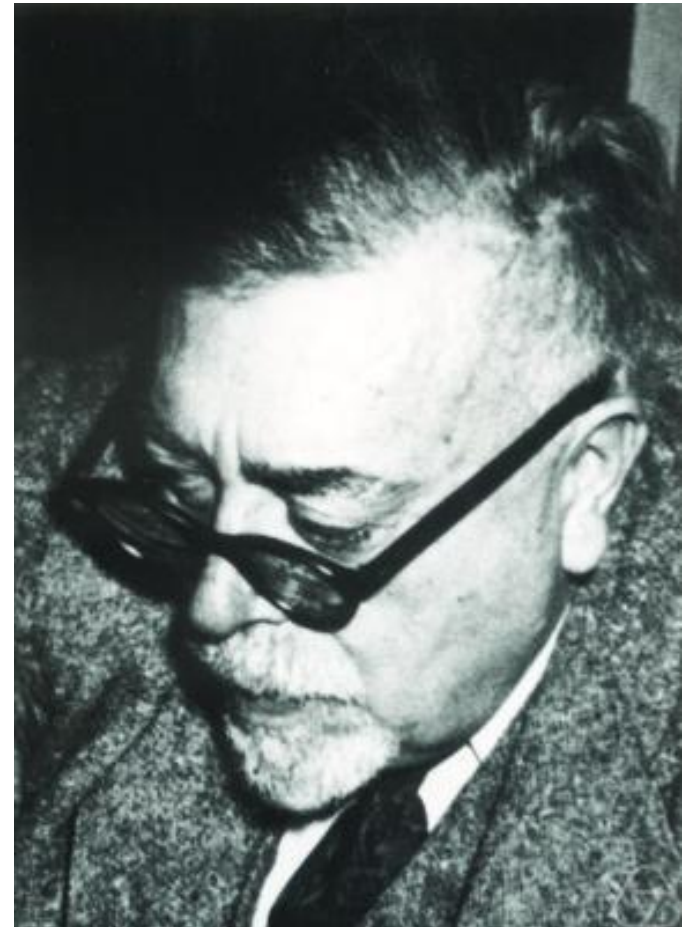

System Transformation

- This expansion is also called a *time-domain variable expansion*:

$$y(t) = h_0(t_0) + \int_{-\infty}^{\infty} h_1(t_1)x(t-t_1)dt_1 + \int_{-\infty}^{\infty} \int_{-\infty}^{\infty} h_2(t_1, t_2)x(t-t_1)x(t-t_2)dt_1 dt_2 + \dots$$

- This linear combination of *convolutions (in the time-domain)* can be mapped to *multiplications in the frequency-domain*.
- Multidimensional (two-sided) Laplace transform (MDLT) techniques can be used to transform the analytical variable system into the frequency domain.
- Taking MDLT from *nontrivial* terms of this Volterra-Wiener functional **power series expansion**, with some **convergence** assumptions, we can write:

$$Y(s_1, s_2, s_3, \dots, s_n) = \lim_{n \rightarrow \infty} \sum_{i=0}^n Y_i(s_1, s_2, s_3, \dots, s_i) =$$

$$\lim_{n \rightarrow \infty} \sum_{i=0}^n H_i(s_1, s_2, s_3, \dots, s_i) X_1(s_1) X_2(s_2) \dots X_i(s_i)$$

- We are interested in response function when $s_1 = s_2 = \dots = s_n = s$, which is called **frequency association [Koh 1975]**.

❖ E. L. Koh, "Association of variables in n-dimensional Laplace transform," *Int. J. Systems Sci*, vol. 6, no. 2,, pp. 127-131, 1975.

System Impulse Response

- The response of an initially unexcited system to the impulse input function is:

$$h(t) = \lim_{n \rightarrow \infty} \sum_{i=0}^n \int_{-\infty}^{\infty} \int_{-\infty}^{\infty} \dots \int_{-\infty}^{\infty} h_i(\tau_1, \tau_2, \tau_3, \dots, \tau_i) \prod_i [\delta(t - \tau_i) d\tau_i]$$

$$h(t) = \lim_{n \rightarrow \infty} \sum_{i=0}^n \int_{-\infty}^{\infty} \int_{-\infty}^{\infty} \dots \int_{-\infty}^{\infty} h_i(\tau_1, \tau_2, \tau_3, \dots, \tau_i) \Big|_{\tau_1 = \tau_2 = \dots = \tau_i = t}$$

- The corresponding transfer function is:

$$H(s) = \lim_{n \rightarrow \infty} \sum_{i=0}^n H_i(s_1, s_2, s_3, \dots, s_i) \Big|_{s_1 = s_2 = \dots = s_i = s} = H_1(s_1) + R_1\{H_2(s_1, s_2)\} + \dots + R_{n-1}\{H_n(s_1, s_2, \dots, s_n)\}$$

- The symbol $R_i\{.\}$ is used to denote the i -th order variables association reduction [Crum 1974].
- To convert the above MDLT function into a single frequency, the technique of *association of variables* is used [Chen 1973].

- ❖ L. A. Crum and J. A. Heinen, "Simultaneous reduction and expansion of multidimensional Laplace transform kernels," *SIAM J. Appl. Math.*, vol. 26, no. 4, pp. 753-771, June 1974.
- ❖ C. F. Chen and R. F. Chiu, "New theorems of association of variables in multiple dimensional Laplace transform," *Int. J. Syst. Sci.*, vol. 4, no. 4, pp. 647-664, 1973.

Recall Multidimensional Laplace Transform

MDLT pairs are defined as [Brilliant 1958]:

$$h(\vec{t}) \Leftrightarrow H(\vec{s}) = \int_0^\infty \int_0^\infty \dots \int_0^\infty h(\vec{t}) e^{-\vec{s} \cdot \vec{t}} \prod_{i=1}^n dt_i$$

$$H(\vec{s}) \Leftrightarrow h(\vec{t}) = \left(\frac{1}{2\pi j}\right)^n \int_{\sigma_n - J\infty}^{\sigma_n + J\infty} \int_{\sigma_{n-1} - J\infty}^{\sigma_{n-1} + J\infty} \dots \int_{\sigma_1 - J\infty}^{\sigma_1 + J\infty} H(\vec{s}) e^{\vec{s} \cdot \vec{t}} \prod_{i=1}^n ds_i$$

where

$$\vec{t} = (t_1, t_2, \dots, t_i)$$

$$\vec{s} = (s_1, s_2, \dots, s_i)$$

$$\vec{s} \cdot \vec{t} = \sum_{i=1}^n s_i t_i$$

Inner Product



❖ M. B. Brilliant, "Theory of analysis of nonlinear systems," M.I.T. Res. Lab. Electro., Tech. Rep. 345, Cambridge, MA, 1958.

Linear Time-Varying Systems

- ❑ For homogeneous linear time-invariant (LTI) systems, all Volterra kernels, except $h_1(t_1)$ are identically zero.
- ❑ For homogeneous linear time-Varying (LTV) systems, the 2nd degree kernel, $h_2(t_1, t_2)$, also exists [Erfani 2009].

$$y_1(t) = \int_R h_2(\tau, t)x_2(\tau, t)d\tau, \quad t \geq 0$$

- ❑ The 1-st degree kernel, $h_1(t_1)$, is the impulse response of $h_2(t_1, t_2)$, and is called the **transient-response** of an initially unexcited LTV systems:

$$\int_R h_2(\tau, t)\delta_1(|t - \tau|)d\tau = h_2(\tau, t)|_{t=\tau} \equiv h_1(\tau), \quad \tau \geq 0$$

where

$$\delta_1(|t - \tau|) = u_1(t - \tau) \times u_1(\tau - t)$$

**AN EQUIVALENT
FUNCTION**

❖ S. Erfani and N. Bayan , “A note on frequency-domain characterization of linear time-varying networks,” *Proc. IEEE ISCAS 2009*, Taipei, Taiwan, pp. 461-464, May 24-27, 2009.

The 2nd and 1st Degree Impulse Responses

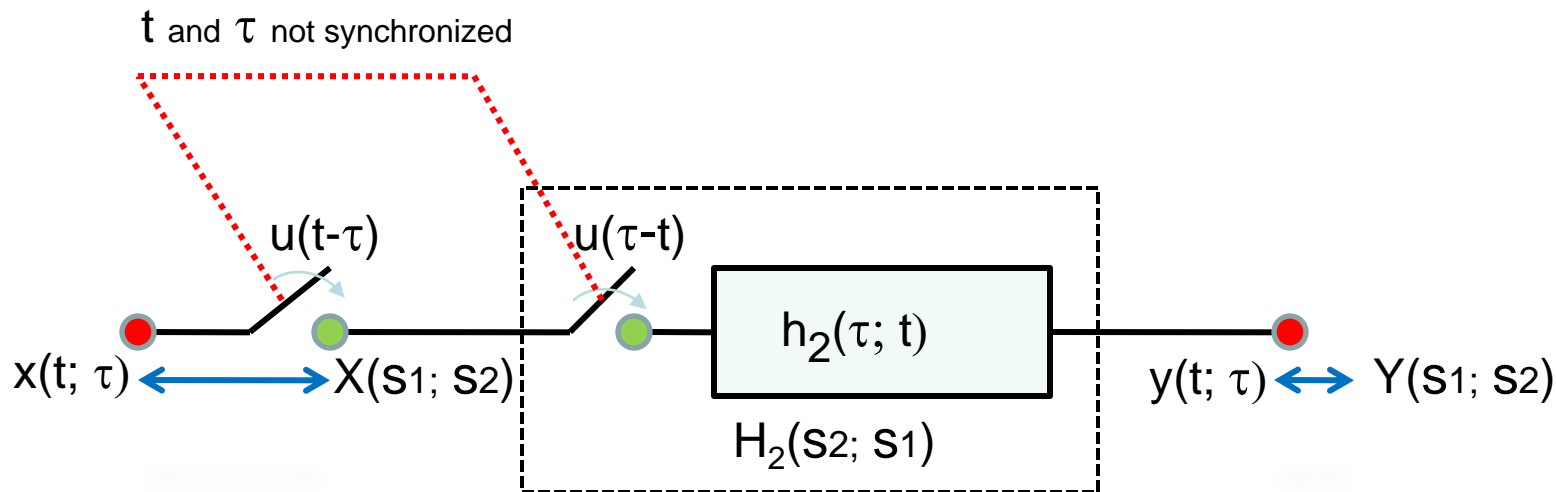

(a)

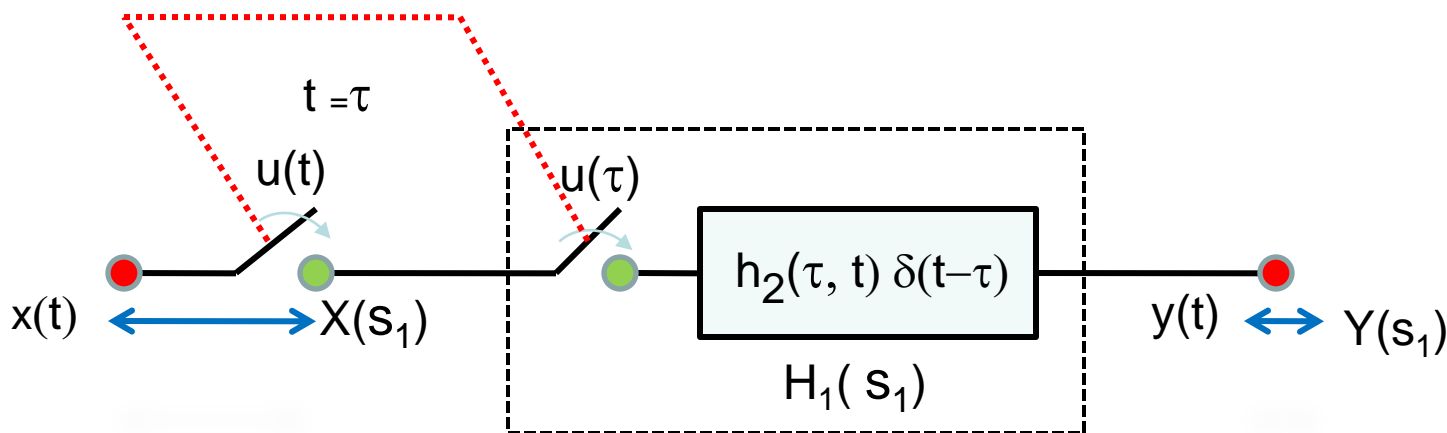

(b)

LTI System Versus LTV System

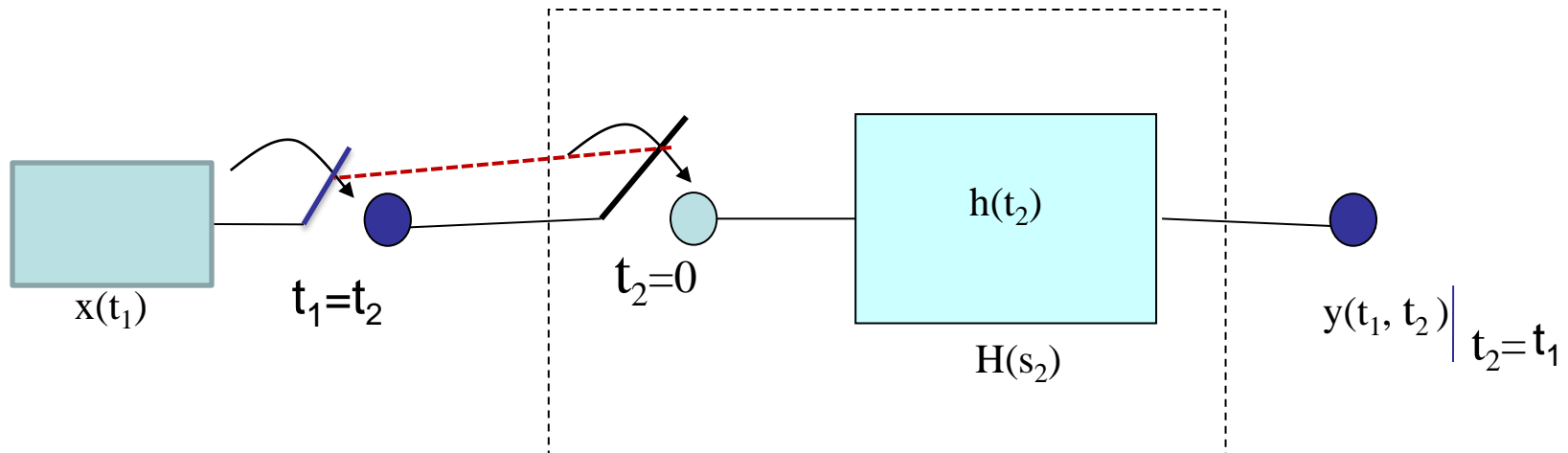

- ❑ t_1 is the observation time of signal and t_2 is the application time to the system.
- ❑ A LTI system equivalent to the *transient response* of an unexcited LTV system function

Linear Time Varying Elements

- A single-input single-output (SISO) *nonanticipative* system element (e.g., a resistor, capacitor, or inductor) of finite order characterized by its input-output relationship is said to be linear if the following holds for each $t, \tau \geq 0$:

$$y_2(t; \tau) = h_1(|\tau - t|)x_2(t; \tau)$$

- where $h_1(\cdot)$ is the system function defines the response at time t , denotes the slope of the y - x curve in a rectangular coordinates system.

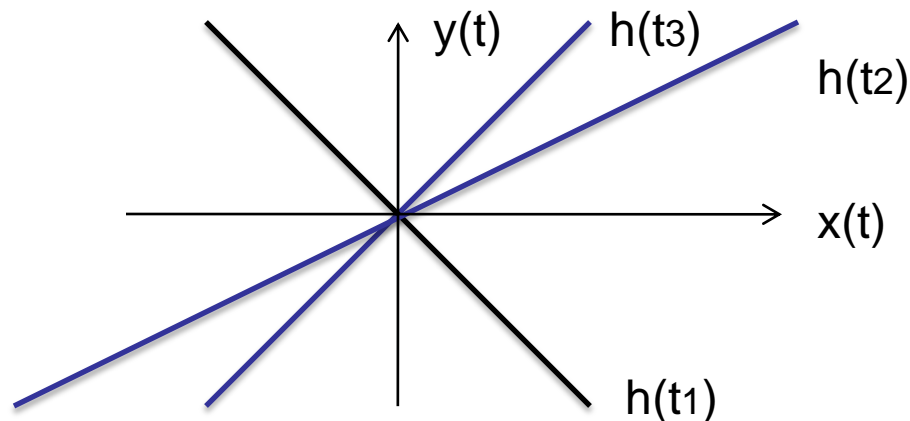

Two-Dimensional Laplace-Carson Transform

- For conformal transformation, it is required that the unit function $u_2(t, \tau)$ transforms into itself:

$$u_2(t, \tau) \Leftrightarrow U_2(s_1, s_2) = 1$$

$u_2(t, \tau)$ is equal to 1 when both t and τ are positive, and is equal to zero when at least one of the arguments is negative.

- Based on the above observation we modify 2DLT as [Ditkin 1962]:

$$h_2(t, \tau) \Leftrightarrow H_2(s_1, s_2) = s_1 s_2 \int_{-\infty}^{+\infty} \int_{-\infty}^{+\infty} h_2(t, \tau) u_2(t, \tau) e^{-s_1 t} e^{-s_2 \tau} dt d\tau$$

Laplace-Carson Transform

❖ V. A. Ditkin and A. P. Prudnikov, *Operational Calculus in Two Variables and Its Applications*, Pergaman Press, 1962.

Characterization of General LTV Systems

- A SISO dynamic LTV system response is derived by variations of observation time t of the input as well as the variations of application time τ of the system:

$$\sum_{i=0}^n a_i(\tau) \frac{d^i y(t)}{dt^i} = \sum_{k=0}^m b_k(\tau) \frac{d^k x(t)}{dt^k}$$

where $t=\tau$ for all $-\infty \leq t, \tau \leq \infty$.

- For a causal and initially unexcited system, if the 2D impulse function $\delta(|t|)u(\tau)$ applied to the system at $t > 0$, we have:

$$\sum_{i=0}^n a_i(\tau) u(\tau) \frac{d^i y(t, \tau)}{dt^i} = \sum_{k=0}^m b_k(\tau) \frac{d^k \delta(t) u(\tau)}{dt^k}$$

we obtain:

$$H(s_1, s_2) = \frac{\sum_{k=0}^m B_k(s_2) s_1^k}{\sum_{i=0}^n A_i(s_2) s_1^i}$$

Laplace Transform of a Delta Function

- The ordinary unilateral Laplace transform of $\delta_1(t - \tau)$ is obtained as:

$$L\{\delta_1(t - \tau)\} = \int_{0-}^{+\infty} \delta_1(t - \tau) e^{-s_1 t} dt = e^{-s_1 \tau}$$

- This is a function of the variable application time τ .
- A second transformation yields:

$$L_{2D}\{\delta_1(t - \tau)\} = \int_{0-}^{+\infty} e^{-s_1 \tau} e^{-s_2 \tau} d\tau = \frac{1}{s_1 + s_2}$$

2DLT

- If t becomes equal to τ , what is the corresponding associated transform?

Associated Transforms

- **Definition** – We define a single-variable function in the time domain corresponding to the bivariate function $h_2(t, \tau)$ such that

$$h_1(t) \equiv h_2(t, \tau) \Big|_{t=\tau}$$

There exists a corresponding 1DLT of $h_1(t)$ such that

$$H_1(s) \Leftrightarrow h_1(t)$$

- This is called the corresponding associated transform and denoted by

$$H_2(s_1, s_2) \mapsto H_1(s_1)$$

- Based on this definition we have the following associated transforms:

$$\frac{1}{s_1 + s_2} \mapsto \frac{1}{s}$$

Two-Dimensional Delta Functions

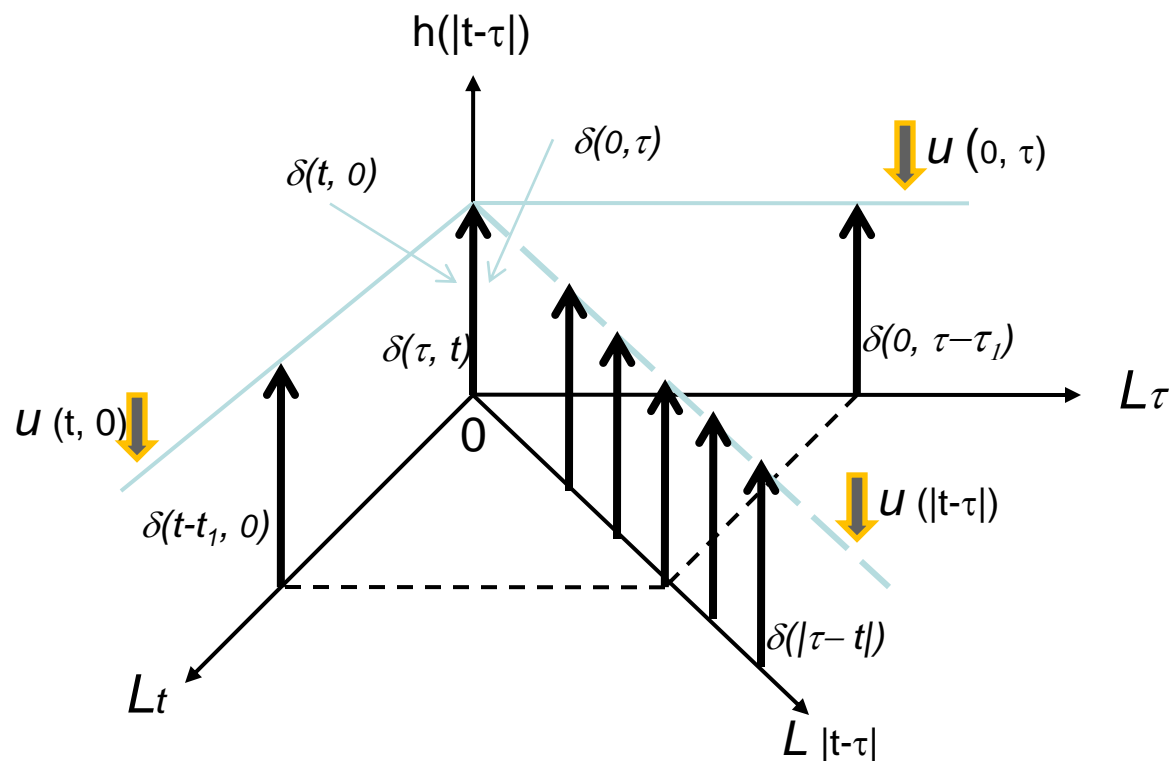

- The 2D unit-impulse functions used to determine an analytic deterministic LTV function as a function of the l_2 norm of the complex quantity $t + j\tau$.

Laplace-Carson Transform of Delta Functions

- The unit-impulse function $\delta(t, \tau)$ is defined as:

$$\delta_2(t, \tau) = \delta_1(t)_1 \delta(\tau)$$

The Laplace-Carson transform of $\delta_1(t-\tau)$ is

$$\Delta_1(s_1, s_2) = s_1 s_2 \int_0^{+\infty} \int_0^{+\infty} \delta_1(t-\tau) e^{-s_1 t} e^{-s_2 \tau} dt d\tau = \frac{s_1 s_2}{s_1 + s_2}$$

Similarly, the L-C transform of $\delta_2(t, \tau)$ is $\delta_2(t, \tau) \Leftrightarrow s_1 s_2$

- We can obtain the L-C transform of $h_1(t)\delta_1(t-\tau)$ as:

$$h_1(t)\delta_1(t-\tau) \Leftrightarrow s_1 s_2 \int_0^{+\infty} h_1(\tau) e^{-(s_1+s_2)\tau} d\tau = \frac{s_1 s_2}{s_1 + s_2} H_1(s_1 + s_2) = \Delta_1(s_1, s_2) H_1(s_1 + s_2)$$

- This is an example of variable expansion from 1D-to-2D.

Characterization of Nonanticipative Systems

❖ Let us define:

$$h_2(t, \tau)u_2(t, \tau) = \begin{cases} h_1(t - \tau)u_1(t - \tau) & \text{for } t > \tau \\ 0 & \text{for } t < \tau \end{cases}$$

❖ The **2DLT** is:

$$H_2(s_1, s_2) = s_1 s_2 \int_0^{+\infty} e^{-s_2 \tau} d\tau \int_{\tau}^{+\infty} e^{-s_1 t} h_1(t - \tau) dt = \frac{s_2 H_1(s_1)}{s_1 + s_2}$$

❖ Similarly, we define :

$$h_2(t, \tau)u_2(t, \tau) = \begin{cases} h_1(\tau - t)u_1(\tau - t) & \text{for } \tau > t \\ 0 & \text{for } \tau < t \end{cases}$$

$$H_2(s_1, s_2) = \frac{s_1 H_1(s_2)}{s_1 + s_2}$$

2DLT

❖ Adding together, we obtain:

$$L_{2D} \{h_1(|t - \tau|)u_2(t, \tau)\} = H_2(s_1, s_2) = \frac{s_2 H_1(s_1) + s_1 H_1(s_2)}{s_1 + s_2}$$



Linear Modulation

- The equivalent resistance of a parallel combination of two **Causal** LTV resistors in the time-domain is given as:

$$R_{eq}(t, \tau) = \begin{cases} R_1(\tau - t) & t < \tau \\ R_1(t - \tau) \parallel R_2(t - \tau) & t \geq \tau \end{cases}$$

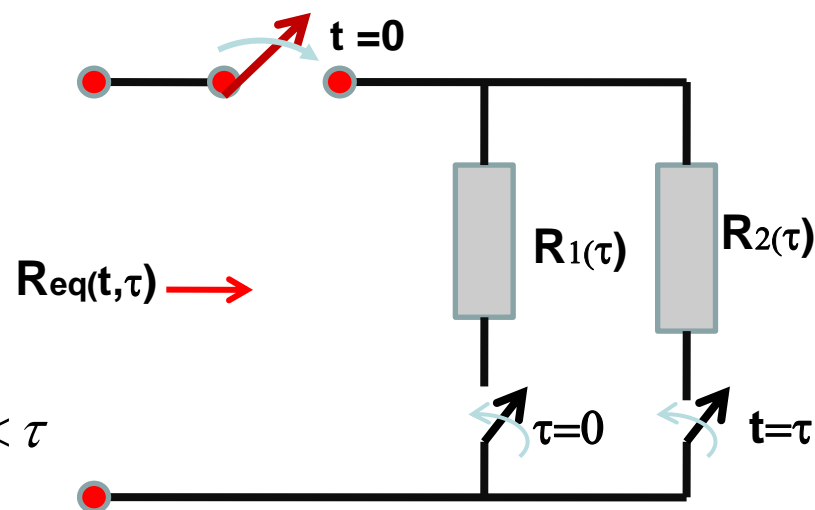

- The equivalent resistance in the frequency-domain, using the 2DLT, is obtained as:

$$R_{eq}(s_1, s_2) = \begin{cases} \frac{s_1}{s_1 + s_2} R_1(s_2) & t < \tau \\ \frac{s_2}{s_1 + s_2} \frac{R_1(s_1)R_2(s_1)}{R_1(s_1)+R_2(s_1)} & t \geq \tau \end{cases}$$

- The equivalent resistance is directly mapped into the **bifrequency-plane**, subject to an extra multiplication by factor $\frac{s_1}{s_1 + s_2} \Leftrightarrow e^{-s_2 t}$. (why?)

Fundamental Transform Relations

| $h(t, \tau)$ | $H(s_1, s_2)$ |
|---|---|
| $\delta(t), \delta(\tau), \delta(t - \tau)$ | $s_1, s_2, s_1 s_2$ |
| $\delta(t - \tau)$ | $\frac{s_1 s_2}{s_1 + s_2}$ |
| $u(t - \tau), u(t, \tau)$ | 1 |
| $e^{-s_2 t}, e^{-s_1 \tau}$ | $\frac{s_1}{s_1 + s_2}, \frac{s_2}{s_1 + s_2}$ |
| $\begin{cases} h(t) & \text{for } t < \tau \\ 0 & \text{for } t > \tau \end{cases}$ | $\frac{s_1 H(s_2)}{s_1 + s_2}$ |
| $\begin{cases} h(t) & \text{for } t < \tau \\ 0 & \text{for } t > \tau \end{cases}$ | $\frac{s_1 H(s_1 + s_2)}{s_1 + s_2}$ |
| $h(t - \tau)$ | $\frac{s_2 H(s_1) + s_1 H(s_2)}{s_1 + s_2}$ |
| $h(t + \tau)$ | $\frac{s_1 H(s_2) - s_2 H(s_1)}{s_1 - s_2}$ |
| $\frac{H(s_1, s_2)}{s_1 + s_2}$ | $\int_0^{\min(\tau, \tau)} h(t - \xi) h_1(\tau - \xi) d\xi$ |

 a
:-

Some Useful Associated Transform Pairs

| 2DLT Function | Associated 1DLT Transform |
|--|--------------------------------|
| $H_2(s_1, s_2) = \frac{1}{s_1 + a} H(s_2)$ | $H_1(s) = H(s + a)$ |
| $Y_2(s_1, s_2) = H_1(s_1)X_1(s_2)$ | $Y_1(s) = H_1(s) \odot X_1(s)$ |
| $Y_2(s_1, s_2) = H_1(s_1 + s_2)X_2(s_1, s_2)$ | $Y_1(s) = H_1(s)X_1(s)$ |
| $H_2(s_1, s_2) = \frac{s_1^n}{s_1 + s_2} H(s_1)$ | $H_1(s) = s^{n-1} H(s)$ |
| $H_2(s_1, s_2) = \frac{1}{s_1} H(s_2)$ | $H_1(s) = H(s)$ |

Using the two-dimensional *frequency shifting*, *frequency convolution*, and *time convolution* properties, one can establish a table of associated transform pairs for *certain* types of 2DLT functions.

Conclusions

- No single approach, via the time-domain or the frequency-domain alone, is sufficient for the development of **adequate analysis and synthesis techniques**.
- A nonlinear dynamic analytic causal deterministic system can be characterized by **MDLT**.
- Properties of MDLT, in general, and 2DLT in particular, make it possible to characterize a large class of LTV systems and circuits such as the entire communication networks.
- Nonlinear **systems**, as well as a **LTV system** that is described by **ordinary linear differential equations with variable coefficients**, can be transformed into algebraic polynomial equations of **two or more** variables, using MDLT properties.
- The **associated transforms** can be used to eliminate the use of unnecessary multidimensional transform tables.

Never, Never, Never Quit. – Winston Churchill

Thank You For Your Attentions

Shervin Erfani

Shervin Erfani is a professor and former Electrical and Computer Engineering Department Head at the University of Windsor, Windsor, Ontario, Canada. His experience spans over 30 years with AT&T Bell Labs, Lucent Technologies, University of Puerto Rico, University of Michigan-Dearborn, Stevens Institute of Technology, and Iranian Naval Academy. His expertise expands over many areas from System Theory to Digital Signal Processing to Network Security Management. He has been a consultant to the industry for a number of years.

Dr. Erfani has published more than 70 technical papers, holds three patents, and is the Senior Technical Editor of the *Journal of Network and Systems Management* and an associate editor for *Computers & Electrical Engineering: An International Journal*.

He received a combined B.Sc. and M.Sc. degree in Electrical Engineering from the University of Tehran in 1971, and M.Sc. and Ph.D. degrees, also in Electrical Engineering, from Southern Methodist University in 1974 and 1976, respectively. He was a Member of Technical Staff at Bell Labs of Lucent Technologies in Holmdel, New Jersey, from 1985 to 2001.

