



Soft-Core Processors For Embedded Systems

Jason G. Tong and Ian D. L. Anderson

Supervisor: Dr. M.A.S. Khalid

ICM'06, December 2006

**Research Center for Integrated Microsystems
Department of Electrical and Computer Engineering
University of Windsor**



OUTLINE

- Introduction
- A Survey of Soft-Core Processors
 - Commercial Cores and Tools
 - Open-source Cores
- Some Example Applications
- Comparison of Soft-Core Processors
- Conclusions and Future Work



Introduction

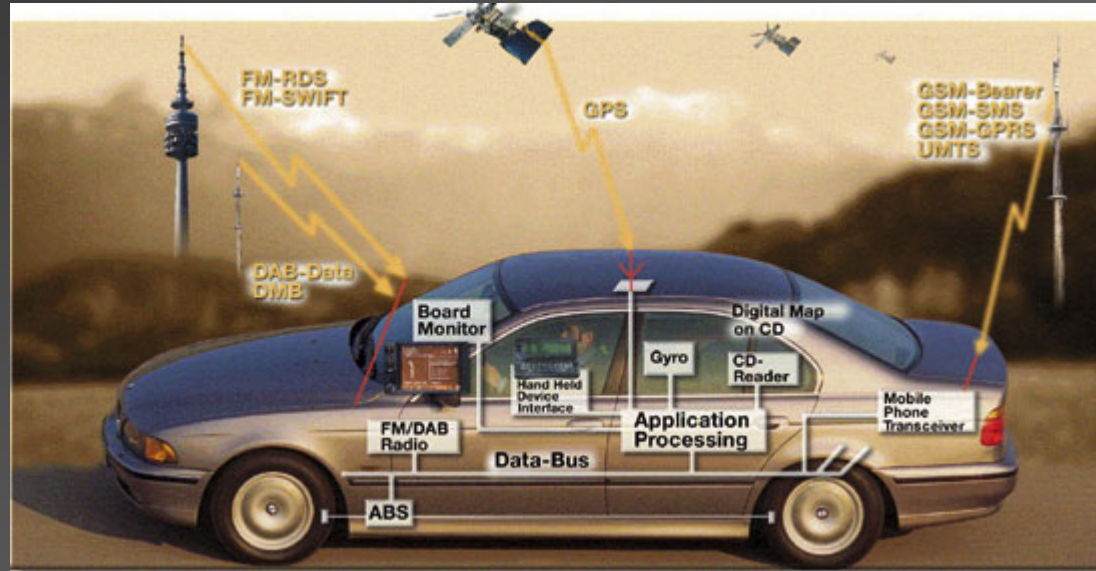

Embedded Systems

- An **embedded system**: a system that utilizes custom hardware and software to carry out specific tasks
- Digital Hardware:
 - **Microprocessor** or μC
 - Application-specific hardware generally used for accelerating time-critical tasks
- **Embedded software** running on the μP or μC

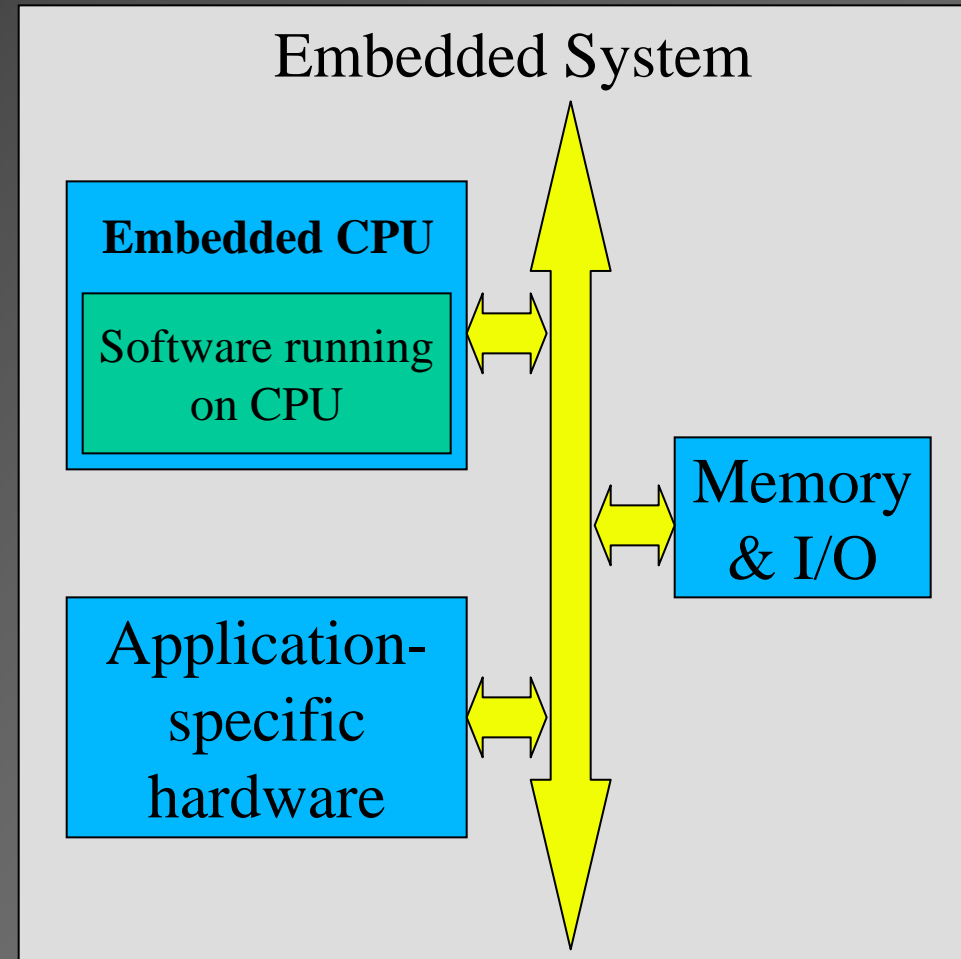

Core-Based Design

- It makes sense for many designers to re-use pre-designed hardware components called “**Intellectual Property (IP) Cores**”
- Reduce design time at the expense of area/performance penalty
- **Soft-core processors** – Complete microprocessors described in a hardware description language (HDL) such as VHDL, Verilog, etc.

Advantages of Soft-Core Processors

- Higher level of **abstraction** – easier to understand
- More **flexible** – designers can change the core by editing source code or selecting parameters (more on that later)
- Platform **independent** – can be synthesized for any IC technology, including FPGAs, ASICs, etc.
 - More immune to obsolescence

A Survey of Soft-Core Processors



Commercial Cores and Tools

- Some of the well known commercial cores are:
 - Altera's **Nios II**
 - Xilinx's **MicroBlaze** and **PicoBlaze**
 - Tensilica's **Xtensa**

Nios II Processor

- Nios II – The second generation of **32-bit Reduced Instruction Set Computer (RISC) Processor** by Altera
- A configurable processor that can be used in many embedded system applications (e.g., Printers, Medical Instrumentation, DVD Players, etc.)
- Targeted for multiple Altera FPGAs (e.g., Cyclone Series FPGAs, Stratix Series FPGAs)
- Instantiated using Altera's System On Programmable Chip (SOPC) CAD Tool

Nios II Processor

- Nios II Processor (A 32-bit RISC Soft-Core Processor)
 - 32 General Purpose Registers
 - 32 Interrupt Request Registers
 - Separate Instruction and Data Cache (up to 64KBytes)
 - Single Instruction 32x32 Multiplier and Divider
 - Dedicated 64-bit and 128-bit multiply instructions
 - Tightly Coupled Memory (TCM) Modules
 - Three variant cores: Economy, Standard, Fast

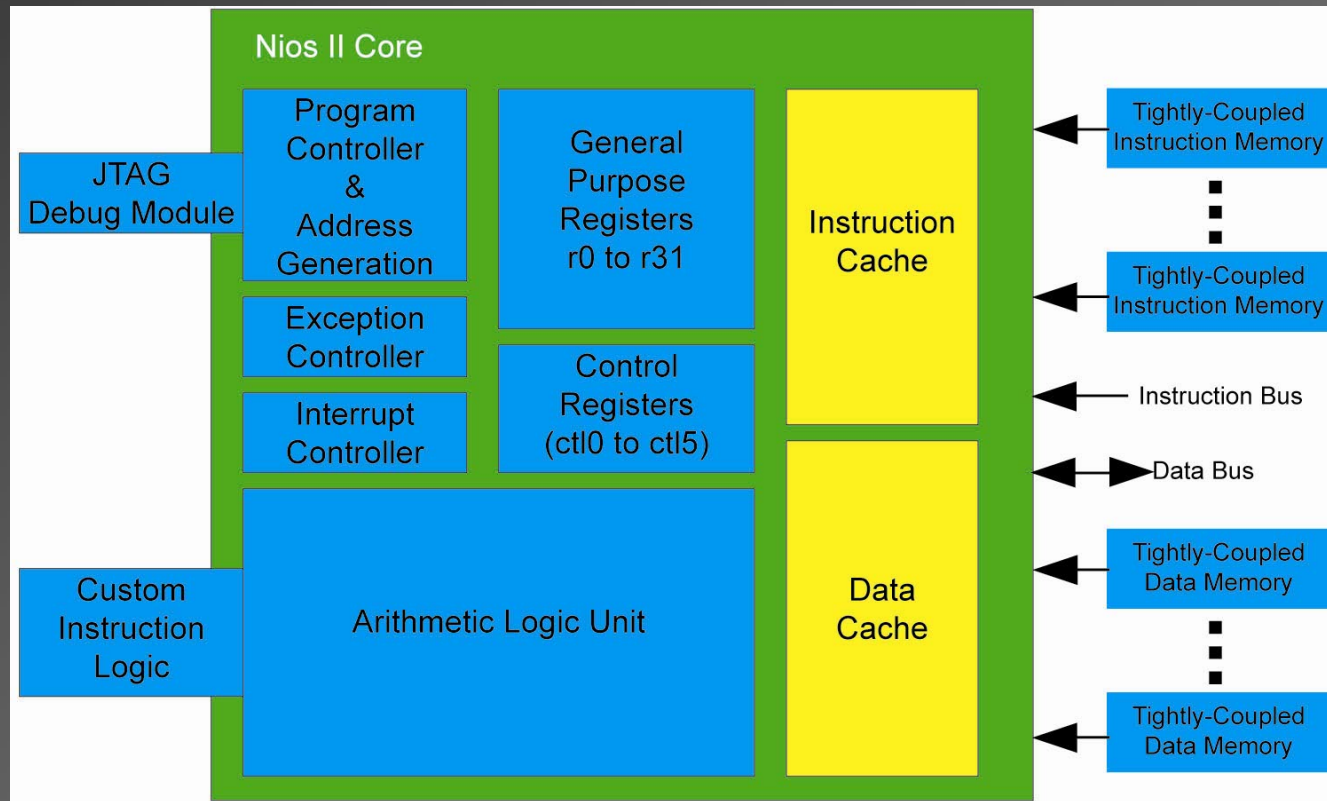

Nios II Processor



Economy Core – Optimized for Area, but provides sufficient performance for small applications (e.g., TV Remote Control, Digital Clock)



Standard Core – Trade off between Economy and Fast cores. Better performance than Economy can offer. But consumes more LEs (e.g., Microwave Oven Controller, DVD Players)



Fast Core – Optimized for best performance on computationally intensive applications. But consumes the most LEs (e.g., multimedia applications)

Courtesy of Paramount and Universal Studios, USA California



Nios II Processor

Comparison Nios II Variants

Features	Nios II Economy	Nios II Standard	Nios II Fast
Objective	Optimized for size	Balance between size and Speed	Optimized for High Performance
Caches (Instruction/Data)	None	Up to 64KB / None	64KB / 64KB
Pipeline Stages	1	5	6
Hardware Multiply	Software Emulated	3 Cycles per MUL	1 Cycle per MUL
Logic Elements used	600-700	1200-1400	1400-1800
Custom Instructions	256 Custom Instructions		

Xilinx MicroBlaze

- **MicroBlaze** – a 32-bit soft-core processor optimized for embedded applications

- Features:

- Harvard RISC architecture
- 32-bit instructions
- 3-stage pipeline
- 32 general-purpose registers
- Shift unit
- 2 levels of interrupt
- Has a number of options including FPU, hardware divider, barrel shifter, caches, etc – save area by not using these options if not needed

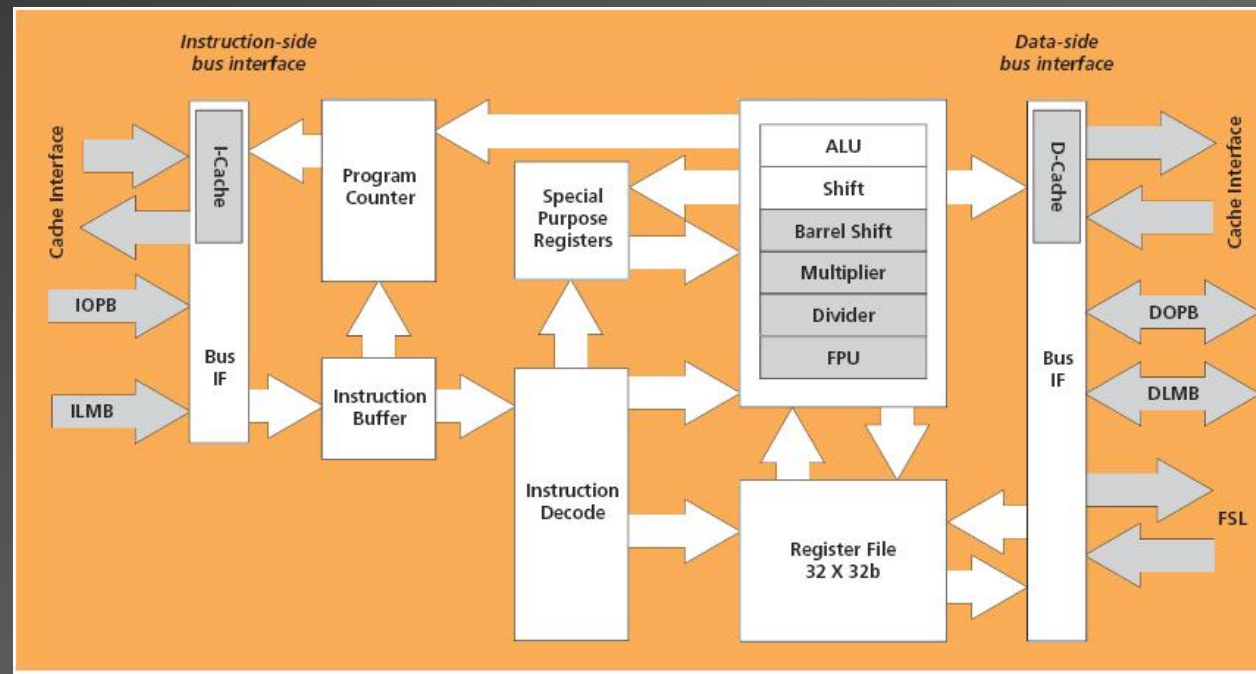

Image Source: MicroBlaze Product Brief
http://www.xilinx.com/bvdocs/ipcenter/product_brief/MB_sell_sheet.pdf

Xilinx MicroBlaze

- Can be connected to on-chip and off-chip peripheral components such using the general-purpose **On-chip Peripheral Bus (OPB)**
- Interfaced to memory via the Local Memory Bus (LMB) or the OPB
- Designers can use the **Fast Simplex Link (FSL)** to interface custom hardware accelerators directly to the pipeline
 - FSL - a low-latency interface to the MicroBlaze pipeline

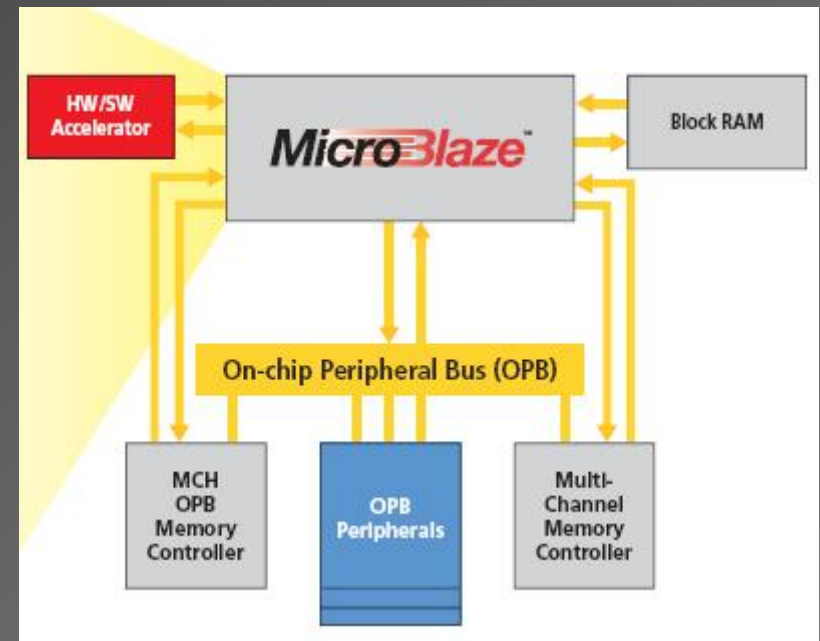

Image Source: MicroBlaze Product Brief
http://www.xilinx.com/bvdocs/ipcenter/product_brief/MB_sell_sheet.pdf

Xilinx PicoBlaze

- A small 8-bit soft-core microcontroller for simple processing applications
- Specifically optimized for the Virtex and Spartan families of FPGAs, and the CoolRunner-II CPLDs
- VHDL source-code can be downloaded for free from Xilinx Inc.'s website

Tensilica Xtensa

- Tensilica's flagship product: the Xtensa Series of “configurable and extensible” processors
- **Configurable**: base core features a set of parameters:
 - Hardware multipliers, single precision IEEE-754 compatible FPU, varying number of interrupts, cache sizes and write policies, variable instruction and data memory sizes, and others
- **Extensible**: designers invent custom instructions using the Tensilica Instruction Extension (TIE) language – a Verilog-like language
 - The TIE instructions are turned into hardware using the TIE compiler

Xtensa Design Environment

- The **Xtensa Xplorer** – a complete design environment for Xtensa processors
- The **XPRES Compiler** can analyze a C/C++ algorithm and automatically create TIE extensions
- The **Xtensa Processor Generator** generates HDL code and Electronic Design Automation (EDA) scripts for a customized processor

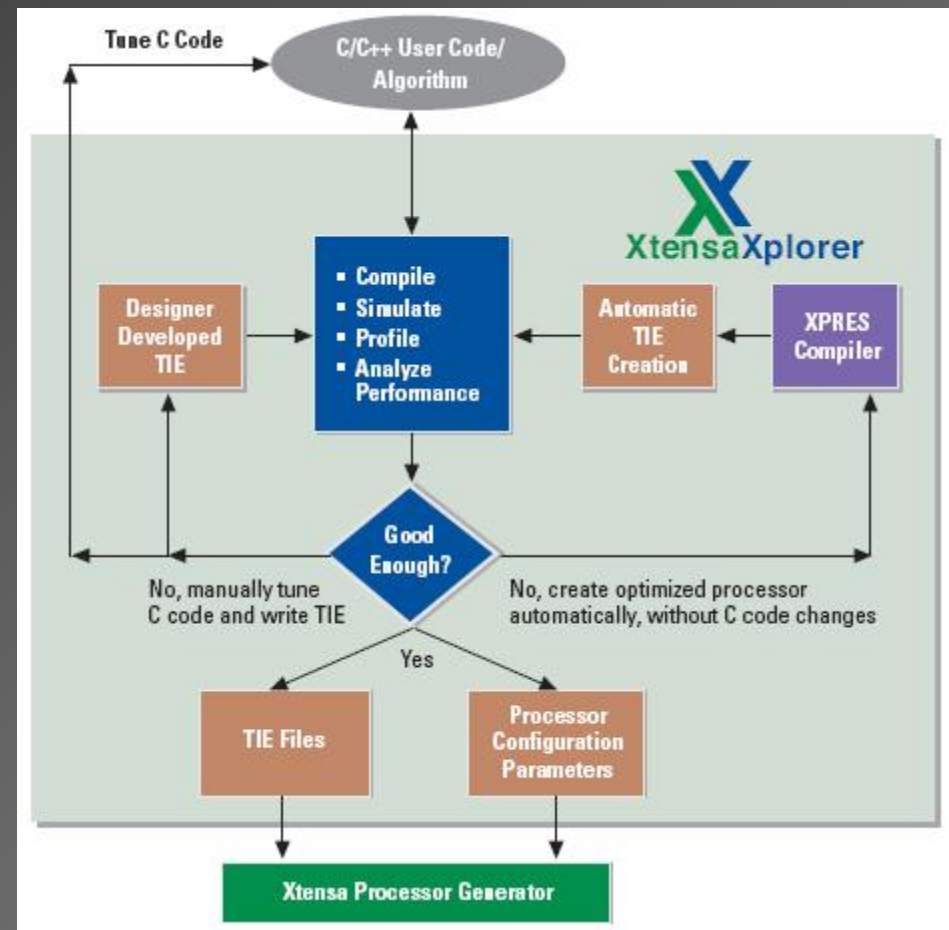

Image Source: Xtensa Developer's Toolkit Product Brief
http://www.tensilica.com/pdf/xtensa_processor_v3.pdf

Open-Source Cores

- There are numerous soft-cores freely available from open-source communities across the internet
- Two will be reviewed:
 - **LEON** by Gaisler Research
 - **OpenRISC 1200** from opencores.org

LEON by Gaisler Research

- The LEON line of synthesizable processors: based on the **SPARC Version 8 architecture**
- LEON2 and LEON3: open-source VHDL models of 32-bit processing cores
- Integer unit fully compliant with IEEE-1754 SPARC V8 standard
- Hardware multiply, divide and multiply-accumulate (MAC) units
- LEON2 – 5-stage pipeline, LEON3 – 7-stage pipeline
- Several peripherals available, including FPUs, timers, UARTs, interrupt controllers, etc.

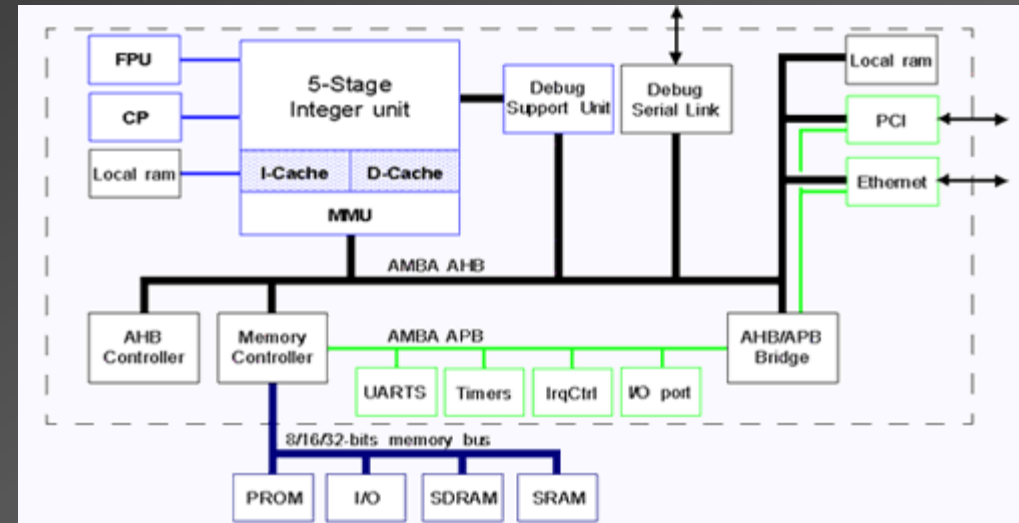

Image Source: LEON2 Processor Overview
http://www.gaisler.com/cms4_5_3/index.php?option=com_content&task=view&id=12&Itemid=52

OpenRISC 1200

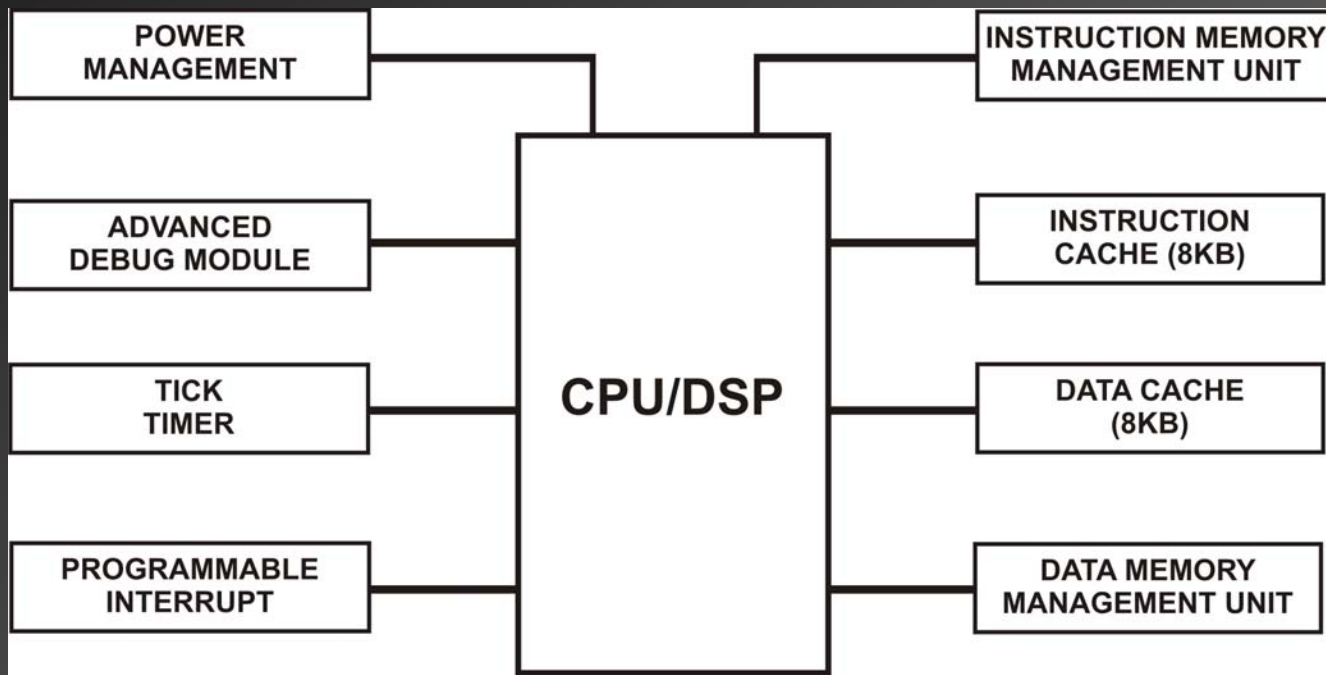

Image Source: OpenRisc 1200

http://www.opencores.org/projects.cgi/web/or1k/openrisc_1200

- One of the popular processors at www.opencores.org
- Contains either a 32/64-bit RISC Architecture and a 5-stage pipelined processor
- Harvard architecture, containing separate 8KB data and instruction memories

OpenRISC 1200

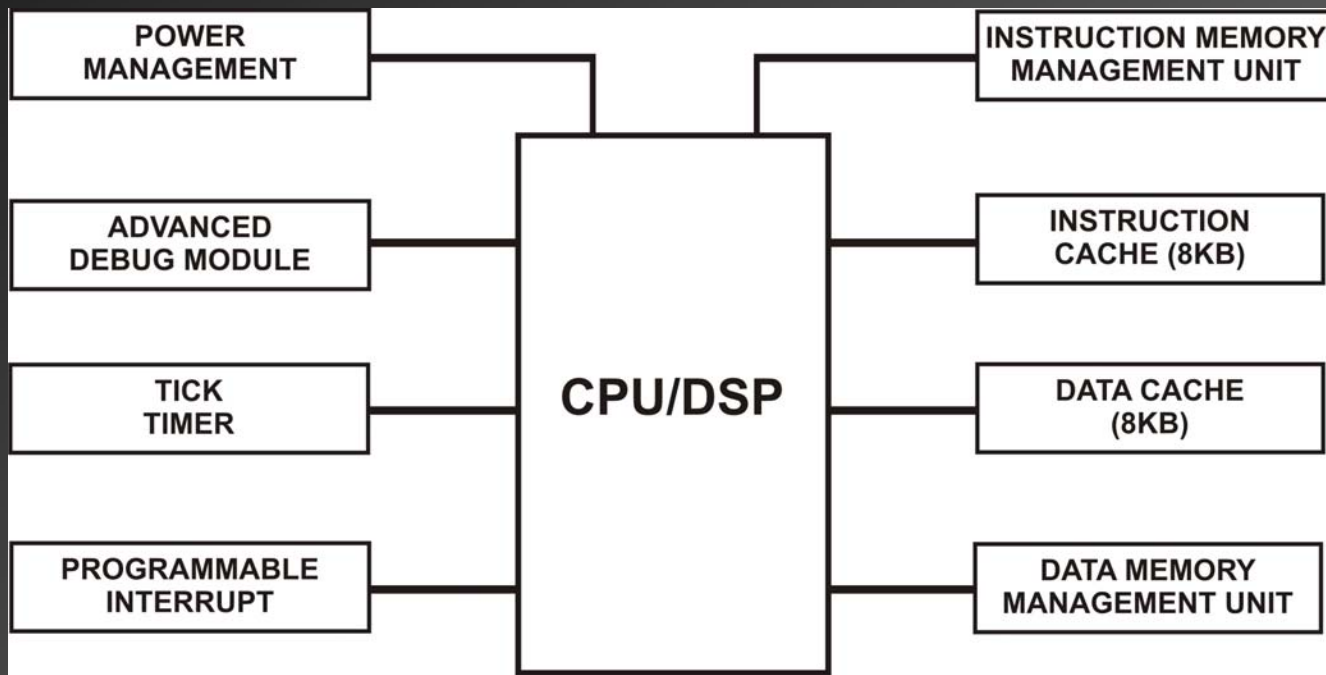

Image Source: OpenRisc 1200

http://www.opencores.org/projects.cgi/web/or1k/openrisc_1200

- High performance CPU/DSP architecture – 32-bit architecture implementing ORBIS32 instruction set
- Advanced Debug Module – non-intrusive debug module for debugging of the OpenRisc processor
- Tick Timer – System Clock Timer
- Instruction/Data Memory Management Unit – Harvard Style memory organization, 8KB of instruction/data cache memories

OpenRISC 1200

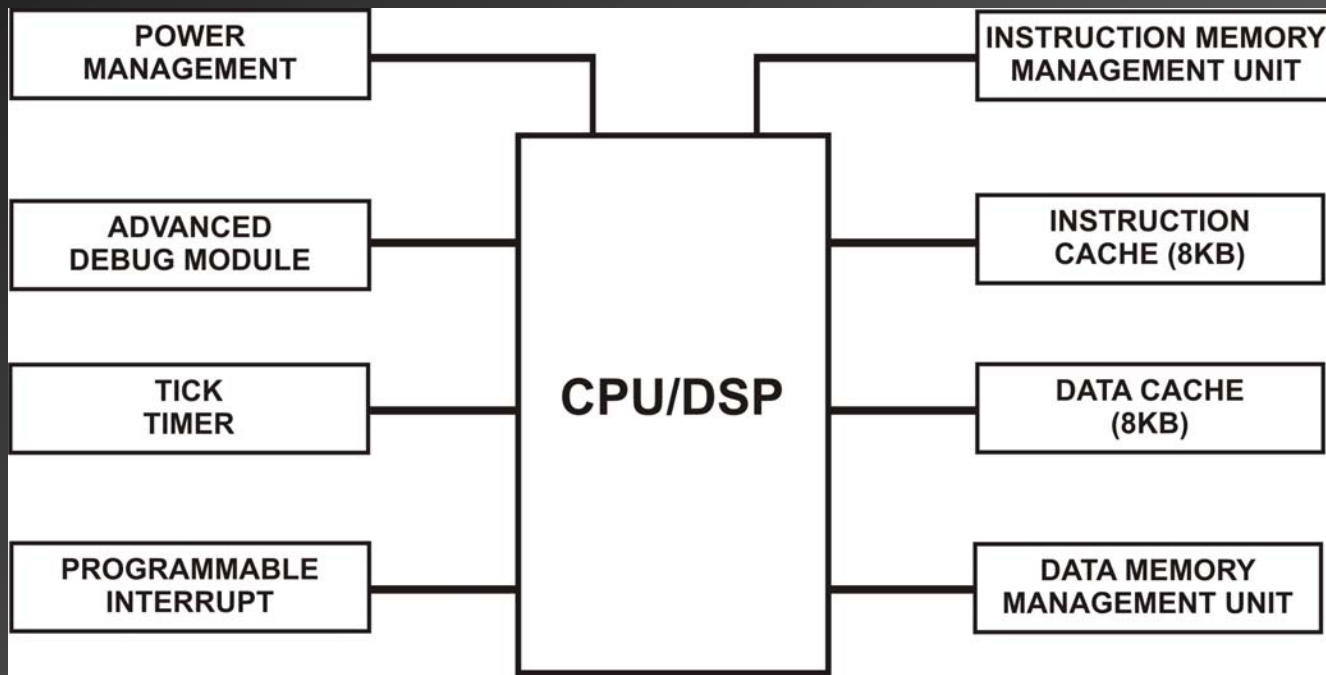

Image Source: OpenRisc 1200

http://www.opencores.org/projects.cgi/web/or1k/openrisc_1200

- Synthesizable and downloadable onto Altera or Xilinx FPGAs
- Real-Time Operating System (RTOS) Support: Linux, Micro-Linux, and OAR RTEMS
- Programming Languages Support: C/C++/Java/Fortran
- Peak Performance: 250MHz and 250DMIPS
- Additional Features: Floating Point Unit and up to 8 peripherals can be connected to the processor core



Some Example Applications



Communications - Broadcom

- Broadcom used the Xtensa Processor in the **BCM1500 Project**
- Designed a class of access communication components for voice, video and data networking
- Five Xtensa Processors were used in their **CALISTO™ architecture** which manages computationally intensive communications functions:
 - e.g. echo cancellation



Image Source: CALISTO VoP Product Brief
<http://www.broadcom.com/collateral/pb/1500VoP-PB03-R.pdf>

Communications – Cisco Systems

- Cisco Systems' **Carrier Routing System** (CRS-1)
- Uses 192 Xtensa Processors in the Cisco Silicon Packet Processor
- CRS-1 is the only carrier routing system capable of scaling up to 92 terabits per second



Image Source: Cisco Carrier Routing System
http://www.cisco.com/application/pdf/en/us/guest/products/ps5763/c1031/cdccont_0900aecd800f8118.pdf

Advertising - AED

- Advanced Electronic Designs (AED) created an **LED sign** for JPMorgan Chase™ in Times Square in New York City
- 135 feet long and 26 feet high with a resolution of nearly 2 million pixels
- Used Virtex and Spartan FPGAs and over **1,000 PicoBlaze processors**
- One main use of processors: Ethernet controllers used to send data to different parts of the sign



Image Source: Sign of the Times
Xilinx Xcell Journal, Winter 2004

Security and Authentication - UCLA

- A team of researchers at UCLA have developed the **ThumbPod** – an FPGA based fingerprint authentication device
- The **LEON2 processor** is used along with two co-processors:
 - Advanced Encryption Standard (AES) processor
 - Discrete Fourier Transform (DFT) processor
- The ThumbPod is able to capture a fingerprint, extract its features and return a score from 0 to 100 indicating the degree of matching

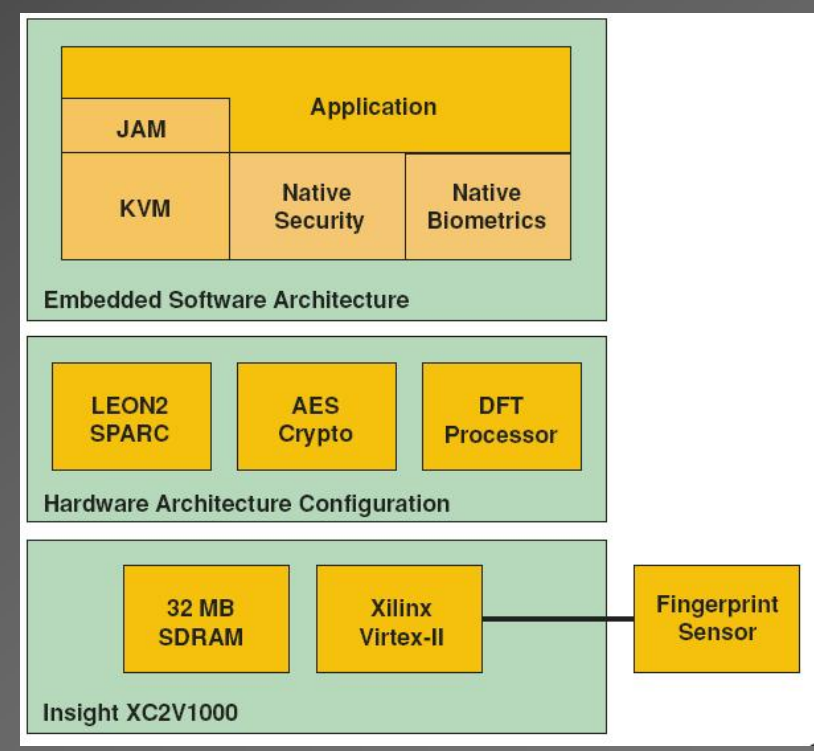

Image Source: ThumbPod Puts Security Under Your Thumb
Xilinx Xcell Journal, Winter 2004



Comparison of Soft-Core Processors

Comparison of Soft-Cores

	Nios II (Fast Core)	MicroBlaze	Xtensa XL	OpenRISC 1200	LEON3
Speed MHz (ASIC/FPGA)	200 MHz (FPGA)	200 MHz (FPGA)	350MHz (ASIC)	300MHz (ASIC)	125MHz/400MHz (FPGA/ASIC)
FPGA/ASIC Tech.	Stratix/ Stratix II	Virtex-4	0.13 micron	0.18 micron	0.13 micron
Reported DMIPS	150 DMIPs	166 DMIPs	N/A	300DMIPS	85DMIPs
ISA	32-bit RISC	32-Bit RISC	32-bit RISC	32 or 64-bit RISC	32-bit RISC
Cache Memory (I/D)	Up to 64KB	Up to 64KB	Up to 32KB (1)	Up to 64KB	Up to 256KB
Floating Point Unit (optional)	IEEE 754	IEEE 754	IEEE 754	as peripheral	IEEE 754
Pipeline	6 Stages	3 Stages	5 Stages	5 Stages	7 Stages
Custom Instructions	Up to 256 Instructions	None	Unlimited	Unspecified limit	None
Register File Size	32	32	32 or 64	32	2-32
Implementation	FPGA	FPGA	FPGA, ASIC	FPGA, ASIC	FPGA/ASIC
Area	700-1800 LEs	1269 LUTs	0.26mm ²	N/A	N/A

(1) – Using 1,2 or 4-way set associative configuration

Comparison of Soft-Cores

- Leon3 has the highest operating frequency of 400MHz using ASIC Implementation
- Nios II and Microblaze, both have the highest operating frequency at 200 MHz on FPGA Implementation
- Tensilica Xtensa offers the greatest flexibility since designers have the ability to implement unlimited custom instructions and execution units in the processor's core
- Majority of the soft-core processors have an optional FPU which is added as a component in the processor's core or as a peripheral

Conclusion and Future Work

- Soft-core processors are becoming an attractive alternative for embedded system design due to the flexibility they offer
 - More wide-spread usage for embedded system design

Related research at RCIM

- A CAD tool is currently under development which enables designers to build soft-core processors and explore various architecture trade-offs (Ian Anderson & Omar Alryahi)
 - Next few slides introduce this CAD tool
- Aws Ismail exploring NoC implementation on FPGAs
- Jason Tong developed an accurate, non-intrusive, FPGA-based SW profiling tool for NIOS II based embedded systems



SCBuild: A CAD Tool for the DSE of Parameterized Cores



Purpose of SCBuild

- “SC” stands for “Soft-core”
- A software tool that performs the following tasks:
 - Facilitates **rapid exploration** of the design space of a parameterized core using the SEAMO algorithm
 - **Generates variants** of a soft-core based on a user-selected set of parameter values
- In other words, the user specifies the parameter values and SCBuild generates a VHDL description of it automatically

SCBuild System Environment

- Template Architect:
generates a **Template Description** for a given hardware component
- SCBuild takes this description and instantiates VHDL components from the Library to create a soft-core
- Also performs DSE using SEAMO algorithm

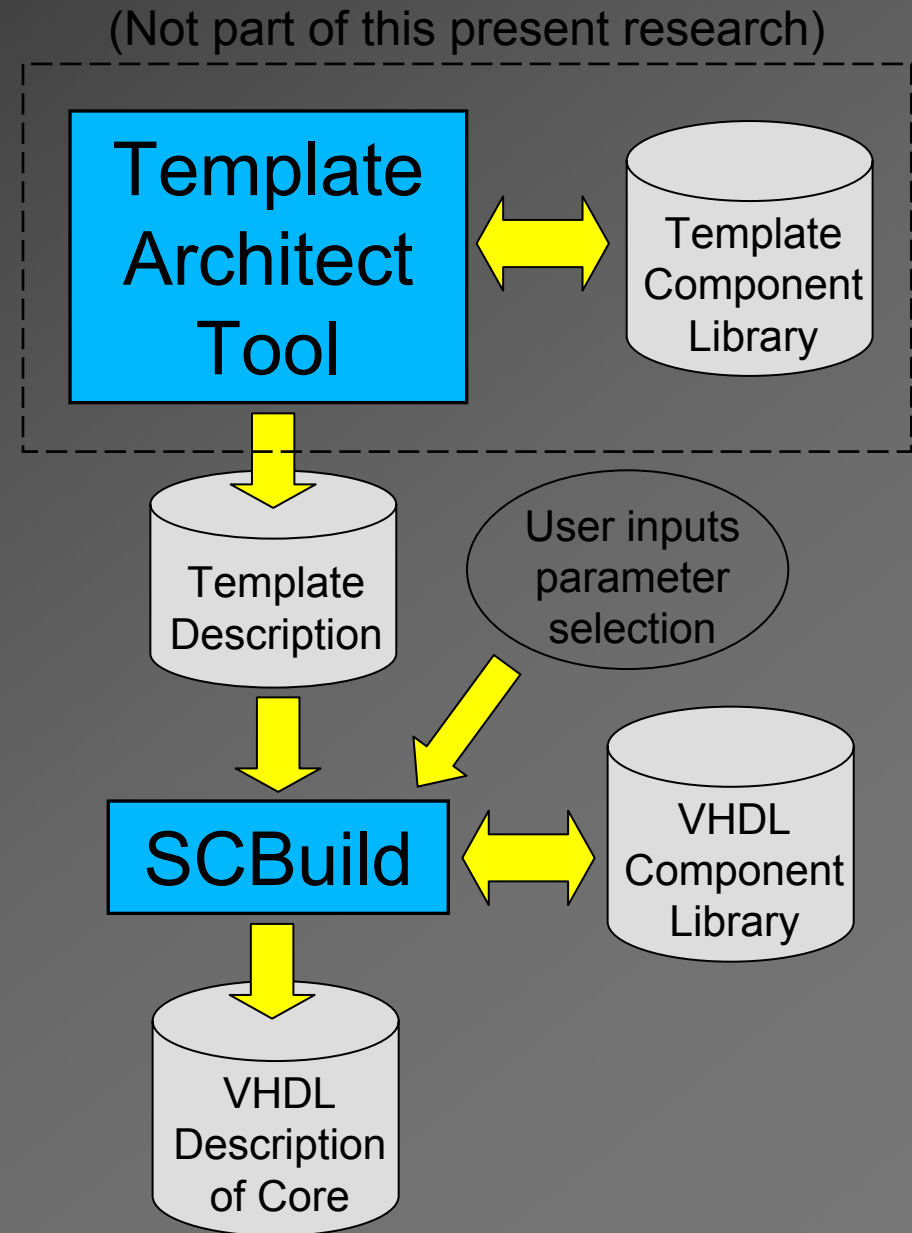



CAD Flow for SCBuild

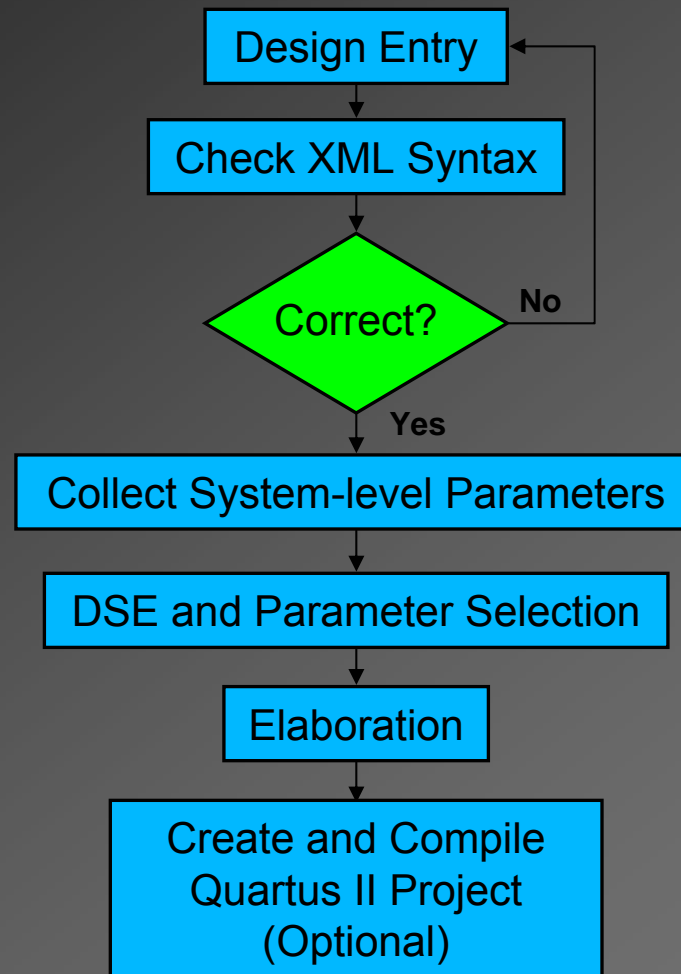

References

- [6] Xilinx Incorporated Website, www.xilinx.com, June 2006
- [7] “MicroBlaze Processor Reference Guide”, Xilinx Corporation, October 5, 2005
- [8] “PicoBlaze 8-bit Embedded Microcontroller User Guide”, Xilinx Corporation, November 21, 2005
- [9] Tensilica Incorporated Website, www.tensilica.com, June 2006
- [10] “Tensilica Diamond Standard Series Product Brief”, Tensilica Incorporated, 2006
- [11] Tom R. Halfhill, “Tensilica’s Preconfigured Cores”, Microprocessor Report, March 20, 2006
- [12] Xtensa Overview, www.tensilica.com/products/overview.htm, June 2006

References

- [13] Create TIE, www.tensilica.com/products/create_tie.htm, September 2006
- [14] TIE Compiler, www.tensilica.com/products/tie_compiler.htm, September 2006
- [15] XPRES Compiler, <http://www.tensilica.com/products/xpres.htm>, September 2006
- [16] Opencores.org Website, www.opencores.org, June 2006
- [17] UT Nios Homepage, www.eecg.toronto.edu/~plavec/utnios.html, June 2006
- [18] OpenSPARC Website, www.opensparc.org, June 2006
- [19] Gaisler Research Website, www.gaisler.com, June 2006
- [20] “LEON2 Processor User’s Manual XST Edition”, Gaisler Research, July 2005

References

- [21] “GRLIB IP Core User’s Manual”, Gaisler Research, February 2006
- [22] Broadcom Website, www.broadcom.com, June 2006
- [23] “Broadcom CALISTO™ BCM1500 Leverages Multiple Xtensa Cores for VoIP ASSP”, Tensilica Incorporated Success Story, 2001
- [24] “Tensilica Technology Helps Power World’s Fastest Router”, Tensilica Incorporated Press Release, August 2, 2004
- [25] Advanced Electronics Designs Incorporated Homepage, <http://www.advanced.pro/>, September 2006
- [26] Daughenbaugh, J., “Sign of the Times, Xilinx makes high-tech outdoor advertising in Times Square possible”, Xilinx Xcell Journal, Winter 2004
- [27] Schaumont, P. and Verbauwhede, I., “ThumbPod puts security under your thumb”, Xilinx Xcell Journal, Winter 2004